

# Waterco pool pumps

Aquamite, Supastream, Supatuf



## **Aquamite**

The Aquamite is an ideal pump for swimming pools and small recirculation systems including ponds and small water features.

## **Supastream**

Supastream pumps are general purpose units designed for use in swimming pools and low pressure water recirculation applications

## **Supatuf**

The Supatuf pump is ideal for large domestic swimming pools with ancillary systems such as heating, in-floor cleaning, fountains, vacuum cleaning and swim jets.



\*conditions apply

**WATERCO**  
Water, the liquid of life

[www.waterco.com](http://www.waterco.com)

### Efficient Impeller and Diffuser Design

The pump's impeller and diffuser design maximizes the hydraulic output of the pump while minimizing turbulence. The pump's efficient hydraulic performance shortens run times and reduces energy consumption leading to lower operating costs.

### Engineered Durability

The pump body is manufactured utilising state of the art engineering plastic moulding with a single piece strainer pot and volute for extra strength.

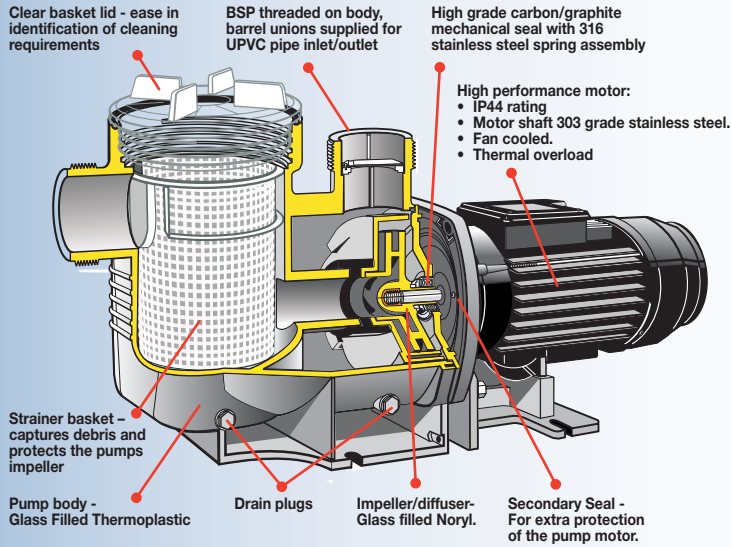

### Waterco's Secondary Seal

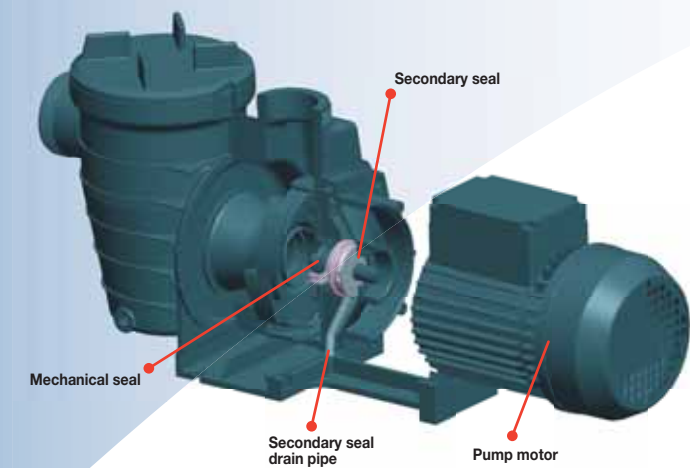

Situated between the pump wet end & the pump motor, a mechanical seal forms a seal around the motor shaft to prevent water from running out along the shaft of a motor. The mechanical seal is the wearing part of any pool pump.

A mechanical seal may leak water if the pump is ever run dry or simply be worn out. If a leaky mechanical seal is not replaced promptly, water will travel up the shaft of the motor and ruin the motor in a very short period of time.

Waterco's Pump Secondary Seal protects the pump motor end shield from any water contact, by capturing any leaks through a worn out mechanical seal and draining it out of the pump.

### Aquamite

The Aquamite is an ideal pump for swimming pools and small recirculation systems including ponds and small water features.



Pump	Inlet / outlet	Strainer basket size
Aquamite	40mm	0.9

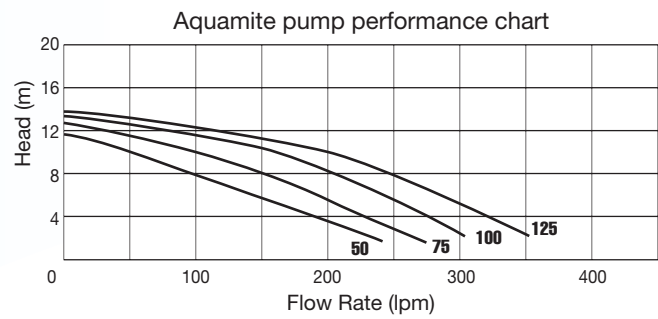

Model No.	Nom. HP	kW	Amps	Total Length	Motor Frame
2402050	0.50	0.58	2.50	497	63
2402075	0.75	0.65	3.00	497	63
2402100	1.00	0.76	3.33	497	63
2402125	1.25	0.88	3.90	497	63

Phase	Volts	Cycle	Rpm
1	220-240	50	2860

### TOTAL LENGTH

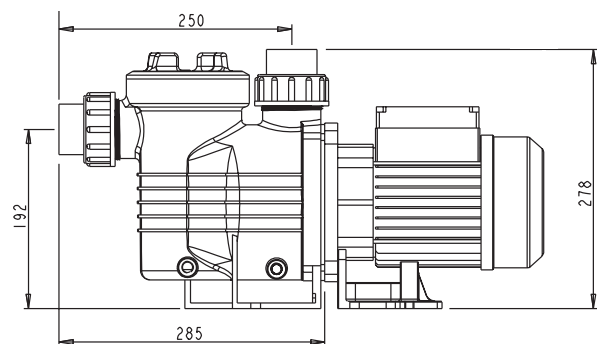

### Supastream

Supastream pumps are general purpose units designed for use in swimming pools and low pressure water re-circulation applications



Pump	Inlet / outlet	Strainer basket size
Supastream	40mm	1.5

Supastream pump performance chart

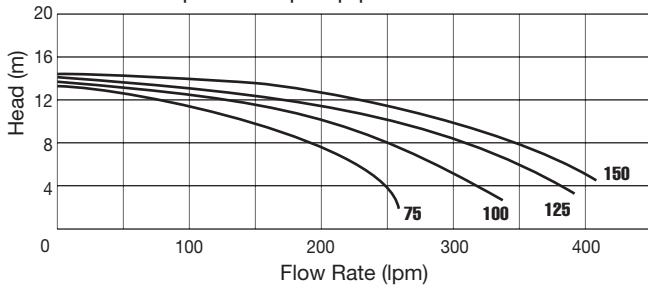

Model No.	Nom. HP	kW	Amps	Total Length	Motor Frame
2403075	0.75	0.61	2.80	536	63
24030100	1.00	0.82	3.60	559	71
24030125	1.25	0.88	3.90	559	71
24030150	1.50	1.09	4.90	580	83

Phase	Volts	Cycle	Rpm
1	220-240	50	2860

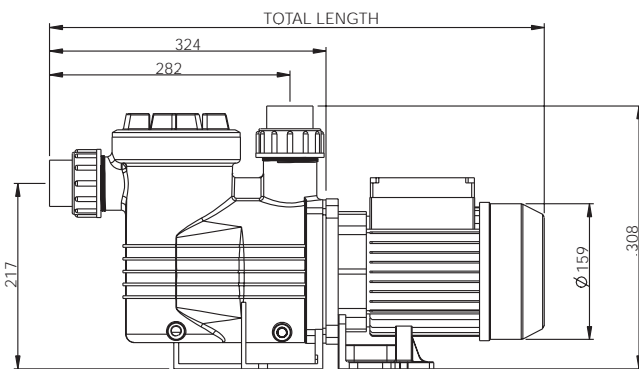

### Supatuf

The Supatuf pump is ideal for large domestic swimming pools with ancillary systems such as heating, in-floor cleaning, fountains, vacuum cleaning and swim jets.



Pump	Inlet / outlet	Strainer basket size
Supatuf	50mm	2.1

Supatuf pump performance chart

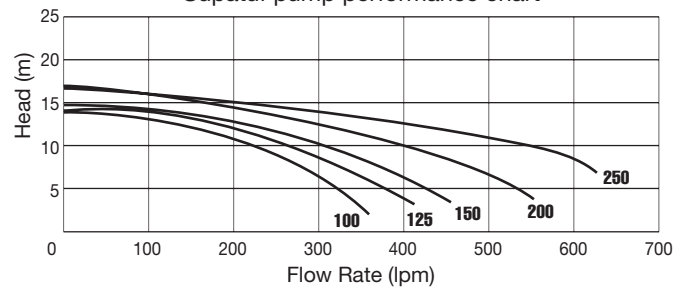

Model No.	Nom. HP	kW	Amps	Total Length	Motor Frame
241100	1.00	0.84	3.70	587	71
241125	1.25	0.96	4.20	587	71
241150	1.50	1.15	5.30	608	80
241200	2.00	1.50	7.20	629	80
241250	2.50	1.81	8.50	653	90

Phase	Volts	Cycle	Rpm
1	220-240	50	2860

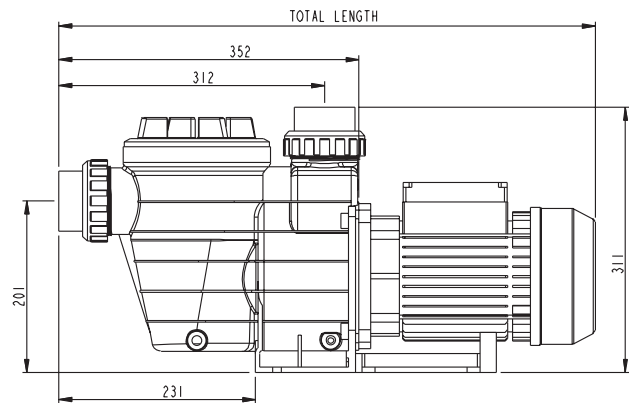



**Warranty**

Pumps	3 years (conditional)*
Wet End	3 years
Motor, Mechanical seal, Hair & lint pot, pot lid & o'ring, basket, impeller & diffuser	2 years
Commercial applications	1 year
Labour	1 year

\* Please refer to Waterco's warranty terms and conditions



**Waterco Limited**

Waterco is an Australian public listed company involved in the manufacture and distribution of:

- Pool and spa equipment
- Pool and spa chemicals
- Domestic water filter, softeners and purifiers
- Commercial water treatment equipment

Waterco exports to over 40 countries via branches operating in Australia, New Zealand, Malaysia, China, the United Kingdom, United States of America, Canada and Indonesia as well as through international distributors.



Aquamite, Supastream and Supatuf are registered trademarks of Waterco Limited.

**OFFICES - AUSTRALIA**

NSW - Sydney (Head Office)  
Tel: +61 2 9898 8686  
QLD - Brisbane  
Tel: +61 7 3299 9900  
VIC/TAS - Melbourne  
Tel: +61 3 9764 1211  
WA - Perth  
Tel: +61 8 9273 1900  
SA/NT - Adelaide  
Tel: +61 8 8244 6000  
ACT Distribution  
Tel: +61 2 6280 6476

**OFFICES - OVERSEAS**

Waterco (Europe) Limited  
Radfield, Kent, UK  
Tel: +44 (0) 1795 521 733  
Waterco USA (Baker Hydro)  
Augusta, USA  
Tel: +1 706 793 7291  
Waterco Canada  
Quebec, Canada  
Tel: +1 450 796 4333  
Waterco (NZ) Limited  
Auckland, New Zealand  
Tel: +64 9 525 7570

Waterco (GZ) Limited  
Guangzhou, China  
Tel: +86 20 3222 2180  
Waterco (Far East) Sdn Bhd  
Selangor, Malaysia  
Tel: +60 3 6145 6000  
PT Waterco Indonesia  
Jakarta, Indonesia  
Tel: +62 21 4585 1481

**DISTRIBUTED BY:**



ZZB1267 05/07